

Drawing for information.
See detail on DWG N° 20-RG1A

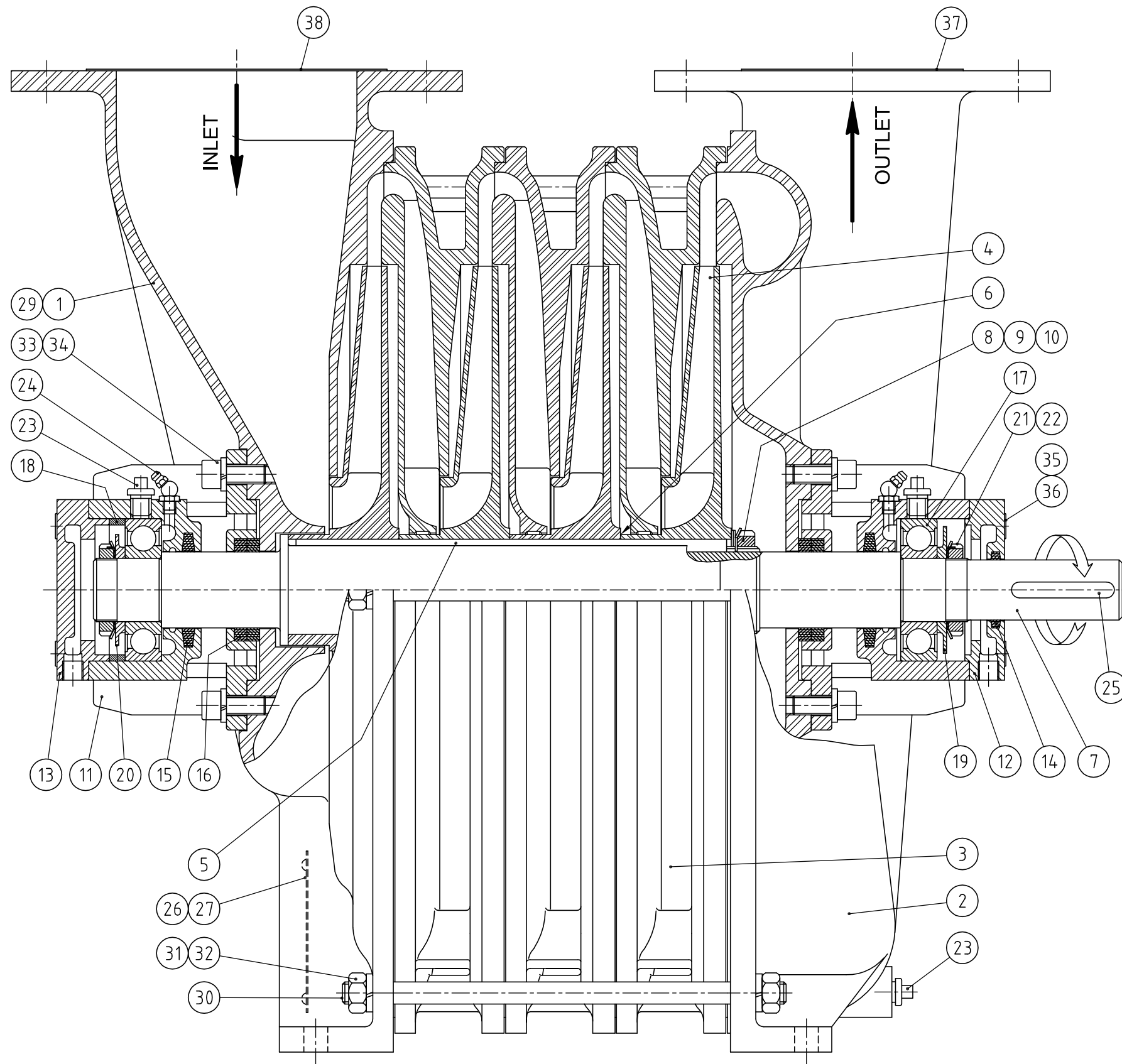

38	1	S.0624	COVER, PORT / DN150			
37	1	S.0417	COVER, PORT / DN125			
36	8	W10	WASHER LOCK, W10			
35	8	CHC M10-025	SCREW, CHC M10-25			
34	8	W12	WASHER LOCK, W12			
33	8	CHC M12-030	SCREW, CHC M12-30			
32	Variable	H M14	NUT, H14			
31	11	W14	WASHER LOCK, W14			
30	6	See 20-RG1A	TIE ROD	010		C.STEEL
29	1	S.1802	VALVE WARNING PLATE	008		
28	1	S.1801	SURGE WARNING PLATE (NOT SHOWN)	092		ALUMINIUM
27	8	CT02.89-008	RIVET, ϕ 2,89-8			
26	1	S.0216	NAME PLATE	284		ALUMINIUM
25	1	S.0408	KEY, COUPLING	003		C.STEEL
24	2	S.0218	CRANKED LUBRICATOR			
23	3	S.0200	PLUG, PIPE 1/4 GAS			
22	2	S.0413	NUT, KM8			
21	2	S.0412	WASHER, MB8			
20	1	S.0463	GREASE, SLINGER ϕ 70 INLET SIDE	10-11		C.STEEL
19	1	S.0407	GREASE, SLINGER ϕ 80 OUTLET SIDE	10-11		C.STEEL
18	1	S.0460	SPACER, BEARING	10-40		C.STEEL
17	2	S.0409	BEARING, BALL 6308 C3			0,63
16	4	S.0454	GRAPHIT RING			
15	2	S.0415	FELT JOINT 48x72x8	005		
14	1	S.0414	FELT JOINT 38x48x4	005		
13	1	S.0458	CAP, BEARING -INLET END	10-26		CAST IRON 1,2
12	1	S.0459	CAP, BEARING -OUTLET END	10-26		CAST IRON 0,8
11	2	S.0455	HOUSING, BEARING	10-24		CAST IRON 6,2
10	1	S.0411	NUT, KM11			
9	1	S.0410	WASHER, MB11			
8	2	S.4322	WASHER, SPRING			C.STEEL
7	1	See 20-RG1A	SHAFT	10-05		C.STEEL 20-RG1A
6	Variable	S.0479	SHIM, IMPELLER	006		C.STEEL
5	1	See 20-RG1A	KEY, IMPELLER	003		C.STEEL
4	Variable	See 20-RG1A	IMPELLER	20-RG1A		ALUMINIUM 3,4
3	Variable	S.4303	SECTION, INTERMEDIATE	20-09		ALUMINIUM 13,2
2	1	S.4302	HEAD, OUTLET	20-02		ALUMINIUM 18
1	1	S.4301	HEAD, INLET	20-01		ALUMINIUM 16
RIEM	NUMBRE	REFERENCE	DESIGNATION	NDR/CAN	MATIERRE	WEISSE/kg

CONTINENTAL
INDUSTRIE

S^tTRIVIER/MOIGNANS
FRANCE

TYPE 020
OUTLET END DRIVE

PARTS LIST
GRAPHIT RING SEAL

ANSEMBLE:
DATE: 29/02/2012
SCALE:
FORMAT: A3 

OUTERATION: Dessiné par: BD
ORDRE Me. N°: Révisé par: DR

DR: DR
N°: DR

N°: DR
20-RG1A-NM

This drawing is not to be used for manufacturing without the approval of the design department.