



CONTINENTAL INDUSTRIE
CENTRIFUGAL BLOWERS AND EXHAUSTERS



BLOWERS & EXHAUSTERS

INSTALLATION, OPERATION
& MAINTENANCE MANUAL



HEAD OFFICE & FACTORY

Route de Bains 01990
Saint Trivier Sur Moignans – France
Tel : +33 4 74 55 88 77
Fax : +33 4 74 55 86 04
www.continental-industrie.com



CONTENTS

INTRODUCTION	1	3.1.2 UNLOADING AND HANDLING	11
		3.1.3 CHECKS	11
		3.1.4 RECOMMENDATIONS FOR LIFTING	11
1. GENERAL INFORMATION	1	3.2 MACHINE STORAGE	12
1.1 SAFETY INSTRUCTIONS	1	3.2.1 SHORT TERM STORAGE	12
1.2 GUARANTEE	1	3.2.2 LONG TERM STORAGE	12
1.3 LIMIT OF LIABILITY	1	3.3 INSTALLATION	12
		3.3.1 INSTALLATION SITE CHARACTERISTICS	12
2. EQUIPMENT DESCRIPTION	1	3.3.2 INLET CONDITIONS	13
2.1 CHARACTERISTICS	1	3.3.3 ADMISSIBLE STATIC STRESSES ON FLANGES	13
2.1.1 GENERALITY	1	3.3.3.1 ACCESSORIES	14
2.2 OPERATION PRINCIPLE	2	3.3.3.2 PIPING	14
2.2.1 SURGE LIMIT	2	3.4 CONNECTIONS - UTILITIES	14
2.3 TYPICAL ASSEMBLY	3	3.4.1 ELECTRICITY SUPPLY	14
2.3.1 BASE PLATE	3	3.4.2 LUBRICATION SYSTEM	14
2.3.2 BASE PLATE FIXING	3	3.4.3 WATER COOLING	14
2.3.2.1 RESILIENT PADS	3	4. START-UP	14
2.3.2.2 LEVELLING PLATES AND FIXING BOLTS	3	4.1 PREPARATION	14
2.3.3 TRANSMISSION	5	4.2 CHECKS	15
2.3.3.1 DIRECT TRANSMISSION	5	4.3 VALVES MOUNTING AND SETTING	15
2.3.3.2 V-BELT DRIVE	5	4.3.1 INLET VALVE	16
2.3.3.3 GEARBOX TRANSMISSION	5	4.3.2 ANTI-SURGE VALVE	16
2.3.4 PAINTING	5	4.3.3 OUTLET VALVE	16
2.4 SPECIAL APPLICATIONS	5	4.4 ROTATION DIRECTION	16
2.4.1 MACHINES FOR HIGH TEMPERATURES	5	4.5 COMMISSIONING	16
2.4.2 MACHINES FOR LOW TEMPERATURES	5		
2.4.3 GAS MACHINES	5	5. BLOWERS AND EXHAUSTERS	
2.5 MOTORS	6	MAINTENANCE	17
2.5.1 MOTOR CONNECTION	6	5.1 MAINTENANCE SCHEDULE	17
2.5.1.1 STAR CONNECTION	6	5.2 MAINTENANCE OPERATIONS	18
2.5.1.2 DELTA CONNECTION	6	5.2.1 LUBRICATION	18
2.5.2 STAR/DELTA START-UP	6	5.2.1.1 GREASE LUBRICATION	18
2.6 TURBINES	7	5.2.1.2 OIL LUBRICATION	19
2.7 INTERNAL COMBUSTION ENGINES	7	5.2.2 V-BELTS DRIVE	20
2.8 HYDRAULIC MOTORS	7	5.2.2.1 V-BELTS REPLACEMENT	20
2.9 ACCESSORIES	7	5.2.2.2 V-BELTS TRANSMISSION ALIGNMENT	21
2.9.1 FLANGED ADAPTOR	7	5.2.2.3 V-BELTS TENSION	22
2.9.2 FLEXIBLE SLEEVE	7	5.2.3 COUPLING ALIGNMENT	22
2.9.3 EXPANSION JOINT	8	5.2.4 BALL BEARING REPLACEMENT	24
2.9.4 BUTTERFLY VALVES	8	5.3 SPARE PARTS	26
2.9.4.1 BUTTERFLY VALVES - MANUAL OPERATION	8	5.3.1 RECOMMENDED LIST	26
2.9.4.2 BUTTERFLY VALVE - PNEUMATIC OPERATION	8	5.3.2 CONSUMABLES	26
2.9.4.3 BUTTERFLY VALVE - ELECTRICAL OPERATION	8	5.3.3 ORDER	26
2.9.5 CHECK VALVE	8		
2.9.6 ANTI-SURGE VALVE	9	6. TROUBLE SHOOTING	26
2.9.7 ANTI-SURGE CIRCUIT	9	6.1 PERFORMANCES REDUCING	26
2.9.8 INLET FILTERING	9	6.2 NOISE PRESSURE LEVEL VARIATION	27
2.9.9 SILENCER	9	6.3 EXCESSIVE OUTLET TEMPERATURE	27
2.9.10 INSTRUMENTATION	10	6.4 EXCESSIVE BEARING TEMPERATURE	27
2.9.10.1 AMMETER	10	6.5 EXCESSIVE ABSORBED POWER	27
2.9.10.2 FLOWMETER	10	6.6 HIGH VIBRATION LEVEL	28
2.9.10.3 PRESSURE GAUGE	10		
2.9.10.4 PRESSURE REGULATOR	10	7. SUPPORT	29
2.9.10.5 THERMOMETER - THERMOSTAT	10	7.1 JOBSITE INTERVENTION	29
2.9.10.6 PRESSURE SWITCH	10	7.2 WORKSHOP SERVICE	29
2.10 SAFETY DEVICES	10		
2.10.1 BEARING TEMPERATURE	10		
2.10.2 VIBRATIONS	10		
3. RECEIPT, STORAGE, AND INSTALLATION OF THE MACHINE	11		
3.1 MACHINE RECEIPT	11		
3.1.1 PRELIMINARY CONTROLS	11		



1. GENERAL INFORMATION

CONTINENTAL blowers and exhausters are made in accordance with current safety regulations.

The various production steps are checked according to the quality controls to ensure that the equipment is free from defects. All machines are mechanically tested before dispatching.

1.1 SAFETY INSTRUCTIONS

General safety standards and any special standard for the specific installation must be applied when handling, installing, using and servicing the equipment.

In particularly:

- Cables and slings must have sufficient resistance and have to be regularly controlled for lifting.
- Only qualified staff is allowed to work on live electrical components.
- Wait the time the capacitors need to be discharged before working on these lines.
- Switch off the isolator and put out appropriate "work in progress" signs while working on machines connected to an electrical supply.
- Check that adequate precautions are taken after every work interruption.
- Mount safety guards before operating machines.
- Prevent access around inlet opening.
- If loose clothing keeps away from rotating parts.

The personnel and people passing near the equipment must be advised against danger to be in contact with:

- potentially hot surfaces of the blowers and exhausters, the pipes and accessories
- parts under tension
- rotating parts

1.2 GUARANTEE

CONTINENTAL equipments are guaranteed twelve (12) months after startup, limited to (18) eighteen months after shipment, for material and manufacturing defects. When it specified in the quotation, some special material is guaranteed six months. The guarantee is limited to replacement and repair of the defective elements at our factory.

To make a claim under guarantee the machines and or systems must have been used for their intended application and in compliance with CONTINENTAL instructions. The purchaser loses all guarantee rights if the machines or systems are repaired or modified without CONTINENTAL agreement. Repairing, modification or

replacements of parts under guarantee don't affect the initial guarantee dates. We don't accept any return of machines without our prior agreement.

Transport cost to our factory will be paid by the purchaser. Nevertheless, and concerning open and hidden defects of the sold object, our contractor guarantee doesn't replace the legal guarantee terms to which all professional sellers are bound. However, the contractual guarantee doesn't imply the right to ask for damages or compensation. We are not responsible for any special destination or dependency not specified in the purchase order.

1.3 LIMIT OF LIABILITY

CONTINENTAL's liability in respect of claims of any kind will not, under any circumstances, exceed the purchase price of the machine and/or system; any claim ends at expiry of guarantee period defined in § 1.2. "Claims of any kind" means any resulting or associated loss and damage, including negligence, from the performance, design, manufacturing, operation, use and, likewise, from any installation, technical installation instructions, inspection, maintenance or repair of any machine or system supplied.

Under no circumstances, either due to breach of the guarantee by CONTINENTAL, or by manifest negligence, CONTINENTAL shall be responsible for special and consequential damages including, without this list being exhaustive:

- Losses of profits or proceeds,
- Losses of the use of the machines, systems themselves or connected machinery
- Capital cost for material or replacement of machines or systems
- Tooling or services involved
- Cost, for down time or purchaser's customers claims for such damages

2. EQUIPMENT DESCRIPTION

2.1 CHARACTERISTICS

2.1.1 GENERALITY

CONTINENTAL INDUSTRIE blowers and exhausters are multi-stage centrifugal compressors intended for the transfer of gaseous fluid.

Their impellers are driven in rotation, by taking the energy required from an external source (e.g. motor, steam turbine, ...), allowing to increase enthalpy level of the moved fluid by increasing its pressure and consequently its temperature.





The basic and efficient design of the CONTINENTAL blowers and exhausters allows keeping stable working features in reducing at the maximum the level of mechanical lost. The only mechanical contacts are onto the ball bearings.

These features depend on the fluid density at the inlet, its composition (Molecular weight) and its characteristics state (pressure and temperature).

To ensure operation in any conditions, the equipment is designed with limit conditions corresponding to the lowest density at the inlet.

The flow rate limits are defined as follows:

- Minimum flow rate: is generally given by the surge point (§ 2.2.1), sometimes by the temperature limit at the outlet (mechanical limit).
- Maximum flow rate: is given by the maximal motor power which must not be overloaded.

Note that load of the machine (blower or exhauster) increases with the density of the fluid at the inlet.

For example, lower temperatures in winter time increase significantly density; that results a significant increase of machine load, outlet pressure and consumed power.

To avoid this phenomenon, pressure regulation can be used as follows:

- Variable Frequency Drive (VFD) to adjust motor speed: As no loss is added, It is the best choice to optimize power consumption
- Butterfly valve at the outlet to meet the nominal working point
- Butterfly valve at the inlet also to meet the nominal working point. In that case, as the density at the inlet is reduced to its initial lowest value, the machine load is also at its minimum value and the consumed power decreases too.

Therefore, to realize an important saving energy, to choose regulation by butterfly valve at the inlet, is better than at the outlet.

2.2 OPERATION PRINCIPLE

For the transfer of a gaseous fluid from one environment to another, we can consider only the evolution of absolute pressure inside the machine. In that case, the atmospheric pressure does not modify the performance of the machine.

As the compressor has always:

- Absolute static pressure at the inlet lower than upstream,

- Absolute static pressure at the outlet higher than downstream,

The CONTINENTAL centrifugal compressor is always both:

- a blower, when one looks at the outlet pressure vs flow rate evolution,
- an exhauster, when one looks at the inlet pressure vs flow rate evolution. We prefer to look at the vacuum created: the pressure difference between the upstream network and the inlet of the machine.

In practice, most of the applications are based on the following additional conditions:

- BLOWER: inlet is open to the atmosphere. If considering inlet pressures losses are insignificant, the blower is characterized by constant pressure at the inlet (equal to atmospheric pressure) and variable pressure at the outlet as a function of the flow rate.

- EXHAUSTER: outlet is open to the atmosphere. If considering outlet pressures losses are insignificant, the exhauster is characterized by a constant outlet pressure (equal to atmospheric pressure) and the inlet pressure varies in function of the flow rate.

2.2.1 SURGE LIMIT

Centrifugal machines are characterized by a limit capacity, below which they are no longer able to develop the pressure (or the negative pressure for an exhauster) required for transferring the fluid from the inlet environment to the outlet environment.

Below this capacity, there is a pressure reversal which makes a flow reversal between those two environments. The phenomenon repeats itself cyclically, generally with a very low frequency (a few Hz), depending on the installation; it can be stopped by increasing the flow (until an upper flow of the surge one).

Operation in these conditions must be absolutely avoided as, when the flow reverses, it generates alternative stress on the impellers vanes, and there is a reversal of the axial thrust on the shaft, which subjects the bearing to fatigue.

In large machines with high compression ratios, surging can be very violent and produce irreversible damage to the impellers and to the piping. In that case, an appropriate safety circuit must be provided.





2.3 TYPICAL ASSEMBLY

The typical assembly for CONTINENTAL blowers and exhausters include a common base plate for motor, machine, machine/motor transmission unit and the protective guard of the transmission unit. The preparation of the holder for equipment fixing is the purchaser responsibility. The metal elements must be treated against corrosion. The foundations must be levelled (lack of flatness < 1 mm) and be designed to avoid the amplification of the vibrations.

2.3.1 BASE PLATE

Small machines are equipped with a base-plate made of folded sheet steel strengthened with appropriate reinforcements Fig. 2.1.

In contrast the other machines have a tack welded base plate Fig. 2.2.

All the base plates have screws to align the motor and to eventually tighten transmission belts. The base-plates must be installed on a horizontal surface, particularly for oil lubricated machines.

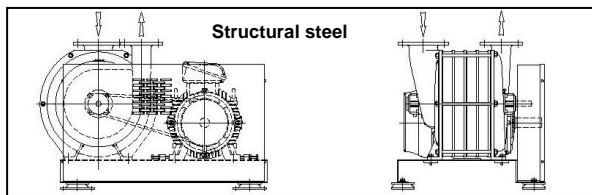

Fig. 2.1

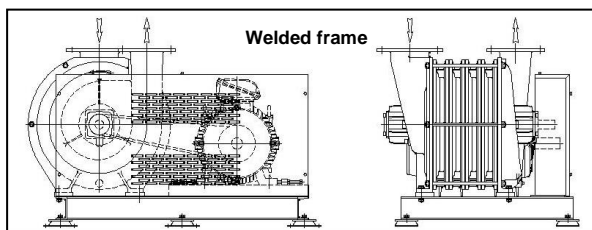
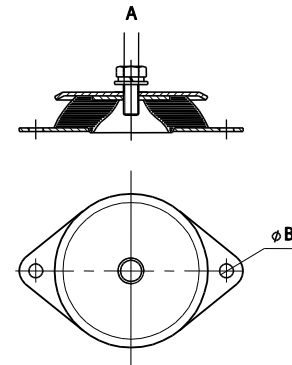

Fig. 2.2

2.3.2 BASE PLATE FIXING

2.3.2.1 Resilient pads

CONTINENTAL machines can be installed on resilient pads. The type and the quantity of pads required are defined by CONTINENTAL according to the machine characteristics.



A= Mounting hole to the frame
B= Mounting hole to the ground

Fig. 2.3

The resilient pads allow the machine to be installed easily and quickly without making special foundations.

In addition of fixing the machine, the pads prevent the transmission of machine vibrations to the environment and reciprocally (transmission of any vibrations present from the surrounding environment).

All the shock absorbing resilient pads must be loaded uniformly to assure the correct operation of the machine.

Corrections often need to be made by placing shims between the resilient pad and the supporting surface.

2.3.2.2 Levelling plates and fixing bolts

Fixing bolts can be provided instead of resilient pads. Anchor bolts are mainly used for machinery with higher power.

To prevent the transmission of vibrations, that installation involves the making of a solid concrete isolated from the rest of the foundations. The installation of the base plate on the foundations must be made according to the following instructions:

1. Make the solid concrete and keep it as much as possible isolated from the rest of the foundation. The upper surface shall be left rough to provide a good link with the concrete screed which will be carried out after.
2. Raise the base plate about one meter above the solid concrete. Fit the levelling screws and the anchor bolts as shown in detail A of Fig. 2.4. Check the 15 mm and 50 mm positions.
3. Lower the base-plate to approximately 200 mm from the solid concrete, and centre the anchor bolts in the pockets. Position the 100 x 100 x 20 plates under the levelling screws. Lower until the levelling screws come into contact with the shims. Position the base-plate in its final location, longitudinally and transversally. Centre the





shims under the levelling screws. Wedge the plates which are not in contact with the adjustment screws. Do not use the screws to make contact with the plates.

4. Check that the anchor bolts are positioned correctly in the pockets. Cement the anchor bolts into their pockets up to the level. Let harden as required.

5. Loosen all the locknuts of the anchor bolts and levelling screws and slightly tighten.

6. Check that the base-plate is leveled by using a spirit level sensitive to 0.02 mm/m or if possible with a laser alignment tool. This check shall be made longitudinally and transversally on all finished surfaces. The flatness shall be to 0.02 mm/m. The levelness is adjusted by using the spirit level on the finished surface as shown in detail C of Fig. 2.4 and using the levelling screw/anchor bolt sets.

Each levelling screw/anchor bolt set can be used to raise or lower the base-plate and therefore the edge of the finished surface relative to the adjacent one.

In particular for:

- lowering, the levelling screw must be loosened and the anchor bolt nut tightened

- rising, the anchor bolt nut must be loosened and the levelling screw tightened.

7. When all surfaces are leveled transversally and longitudinally as specified, ensure that no screws or nuts are loosened. If they are, they must be tightened manually so as not to disturb the level obtained. All lock nuts are also to be tightened manually.

8. Clean the surfaces of the solid concrete and prepare it for flow the cement. Provide an enclosure as shown in detail B of Fig. 2.4. If it is installed in the open air, provide appropriate drainage for rainwater, by taking into account the base-plate shape. Flow low shrinkage cement under the base-plate up to the level indicated in detail B. Do not use mechanical vibrators which may compromise the surface levelling obtained.

9. Wait few days up to obtain a complete drying.

10. Tighten all the anchor bolt nuts and the associated lock nuts before mounting the machines.

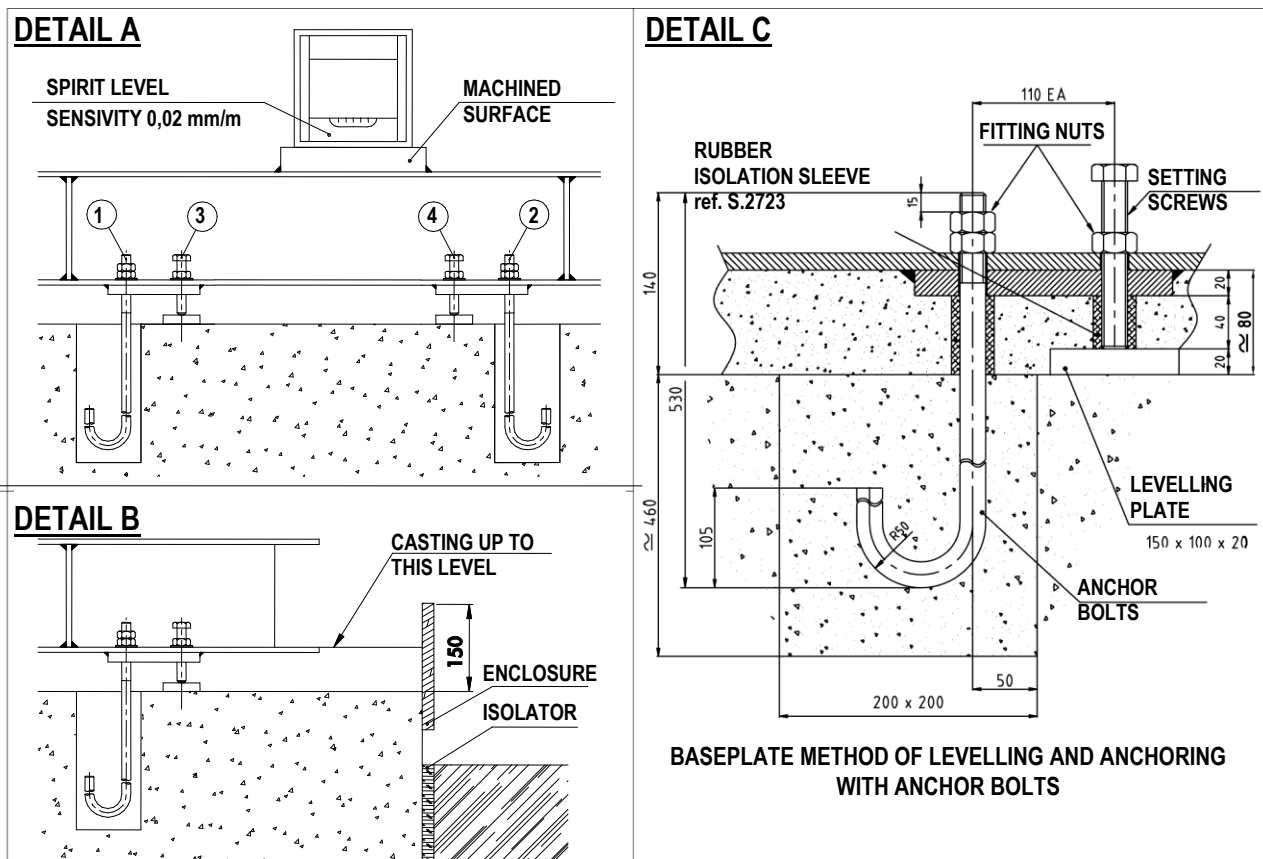

Fig. 2.4





2.3.3 TRANSMISSION

Any coupling element is protected by an aluminum or steel guard.

2.3.3.1 Direct transmission

Direct drive ensures the machine rotational speed is equal to the one of the motor. The coupling commonly used is "lamellar" type. A spacer enables the replacement of the ball bearing at the coupling end, without disturbing the alignment.

2.3.3.2 V-belt drive

V-belts drive is widely used. It allows the choice of the optimum rotation speed and optimizing the efficiency of the machine. If desired, it allows changing the performance curves of the machine to a certain extent by the simple change of pulleys set. In many cases the use of 4-pole motors is possible to lower the overall noise level of the unit. Refer to § 5.2.2.2 for alignment and tensioning of the transmission belts.

- The machine shall never exceed plated speed without preliminary authorization of CONTINENTAL

2.3.3.3 Gearbox transmission

We use a gearbox when we want to use the machine at a higher speed than the motor and when the power is too high for using a V-belt.

The position of the gearbox, mounted directly on fabricated holder, is fixed.

The alignment is achieved only by longitudinal and lateral movements of the machine and the motor with the screws provided for this purpose. Any height adjustments are obtained by changing the value of shims under the brackets of the machine and the motor.

The lubrication circuit of the gearbox requires additional controls: refer to the instructions of the gearbox.

2.3.4 PAINTING

The standard painting of CONTINENTAL blowers and exhausters and their common accessories consists of a base coat applied after brushing and degreasing and a finishing coat in grey RAL 7016.

The corrosive atmospheres will be the subject of a detailed attention; to keep the safety level required, the painting of protection is only performed at the factory.

2.4 SPECIAL APPLICATIONS

2.4.1 MACHINES FOR HIGH TEMPERATURES

Where machines operate at a high temperature, a water-cooling circuit for bearings can be used in addition to possible deviations from standard models with regard to tolerances and the materials for certain items

When necessary, specific instructions will be provided separately with regard to the above features and the lubricants to be used.

2.4.2 MACHINES FOR LOW TEMPERATURES

Where machines are to operate at low temperatures, the following measures can be taken in addition to possible deviations from standard models with regard to the materials for certain items:

- Circuit to preheat bearings before start-up.

When necessary, specific instructions will be provided separately with regard to the above features and the lubricants to be used.

2.4.3 GAS MACHINES

Where the fluid processed is a gas other than air, various measures can be adopted depending on the particular characteristics of the application and the gas itself:

- The inside of the machine body can be given a gas-proofing treatment to prevent gas losses to the environment via casting pores
- Fitting of the machine safety housing
- Use of special belts and/or transmission couplings for the spark-proof models
- Use of special coupling guards for the sparkproof models
- Mechanical shaft sealing to minimize losses of the gas processed into the environment
- Sealing of the shaft by injection of the same gas processed to prevent contamination of the gas by atmospheric air
- Sealing of the shaft by the injection of inert gases to prevent losses of the gas processed into the environment
- Use of special materials for rotors and/or the shaft
- Use of protective coatings for rotors and/or the machine body interior.

When necessary, specific instructions are provided separately with regard to the above features.





2.5 MOTORS

The mechanical energy required to run CONTINENTAL blowers and exhausters is in the majority of cases taken from an electric motor.

NOTE: Usual instructions for motor have to be strictly respected (number of consecutive starts, etc...).

2.5.1 MOTOR CONNECTION

IMPORTANT: all interventions on electric motors must be carried out only by qualified personnel.

All electrical motors must be individually earthed using a cable of appropriate size.

Commonly, electric motors are fed with three-phase alternative current.

The windings of the electric motor lead to 6 terminals in a terminal box with cable glands for the alimentation. The terminal box is located on the top or on the side of the motor. The terminals are arranged and designated as illustrated in Fig. 2.5 and Fig. 2.6.

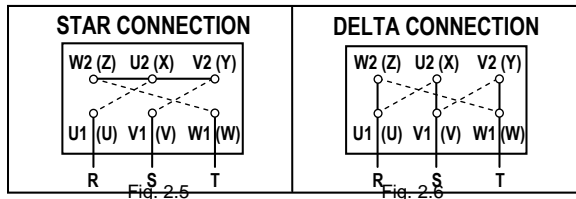

In some cases, there can also be terminals to connect special devices such as resistance heaters or RTDs (resistance temperature detectors) to measure the windings temperature. The main characteristic data is stamped on the metal name plate of every motor. The motors must always be connected downstream from suitable protection against overloads and short circuits. The motors may be designed to operate in a single direction of rotation. Often, the cooling fan vanes are orientated according to that rotation direction, in order to get a better cooling efficiency and cause less noise.

2.5.1.1 Star connection

The star connection is used where the line voltage is equal to the higher of the two voltages given on the nameplate (the line voltage is the potential difference between two of the three conductors R, S and T).

The three links fitted in the terminal box must be set out as shown in Fig. 2.5

At the first start-up, the rotation direction must always be checked; if necessary it can be changed, by swapping two of the three supply cables R, S and T.

2.5.1.2 Delta connection

The delta connection is used where the line voltage is equal to the lower of the two voltages given on the nameplate (the line voltage is the potential difference between two of the three conductors R, S and T).

Apart from factors due to the electricity supply line, there are no objections to a direct start-up the electric motors coupled to CONTINENTAL blowers and exhausters.

Direct start-up consists of powering the motor directly at standard operating voltage. This allows the motor to develop the maximal acceleration torque and thus to reduce, to a minimum, the time required to reach the nominal speed of rotation. Naturally, maximum current absorption corresponds to the maximum acceleration torque.

2.5.2 STAR/DELTA START-UP

To reduce the load on the supply line and to contain the absorption peaks, star-delta start-up is often used for motors with power over 7.5 kW.

The star-delta start-up consists of powering the motor at a voltage lower than the nominal one until its rotation speed is close to the nominal one (some seconds) and then moving to a full voltage supply.

This is only possible where the line voltage is the lower of the two voltages given on the plate (the line voltage is the potential difference between two of the three conductors R, S and T).

In the first mode, the motor has a star connection and therefore the line voltage is 1.73 times lower than its nominal voltage. The current absorption and the acceleration torque are approximately one third of their maximum value and therefore the time required to reach values close to the nominal speed of rotation is longer than with direct start-up.

In the second mode, the motor has a delta connection and therefore the line voltage is equal to the nominal supply voltage. Absorption and acceleration torque may now reach their maximum values but the machine is already close to its nominal speed of rotation and requires only a small final acceleration.





The star/delta start-up involves removing all the terminal box strips and connecting six separate cables, one for each corresponding terminal.

To reverse the direction of rotation, two of the three cables connected to one side of the terminal box and the two opposite cables on the other side of the terminal box must be swapped.

In view of the relatively long start-up times typical for multistage centrifugal blowers and exhausters, the use of thermal protection is recommended downstream to the electrical supply contactor.

2.6 TURBINES

Direct turbine coupling is generally used because of the specific characteristics of the installation. Specific instructions are provided separately.

2.7 INTERNAL COMBUSTION ENGINES

The use of internal combustion engines is generally restricted to machines installed on self-propelled equipment and machines in fixed installations where there are plenty of natural or biological gases.

A clutch is inserted between the motor and the transmission which can be made by belts and pulleys or by a gearbox.

Specific instructions are provided separately.

2.8 HYDRAULIC MOTORS

The use of hydraulic motors is generally restricted to machines installed on self-propelled equipment.

The hydraulic motor is supplied with pressurized oil by the main motor of the equipment itself.

Transmission is usually by means of belts and pulleys.

Specific instructions are provided separately.

2.9 ACCESSORIES

Depending on the application for which CONTINENTAL blowers and exhausters are intended, they can be provided with certain accessories to enhance the installation and enable it to be used correctly. The accessories mounting must not involve stresses or moments superior to those defined into § 3.3.3.

2.9.1 FLANGED ADAPTOR

The flanged adaptor, comprising a piece of tube welded to a mating flange, is used together with a flexible sleeve to connect the inlet and/or outlet port to the piping of the system to be served. The connection thus made prevents the transmission of vibrations from and to the machine and enables thermal expansion to be absorbed. The fittings and the pipes connected above the adaptor must be appropriately fixed so that they do not rest on the adapter itself

2.9.2 FLEXIBLE SLEEVE

The flexible sleeve (Fig. 2.8), made of reinforced rubber, is intended for fitting with the flanged adaptor described in item 2.9.1.

The flexible sleeve is secured to both the tubes connected by two straps.

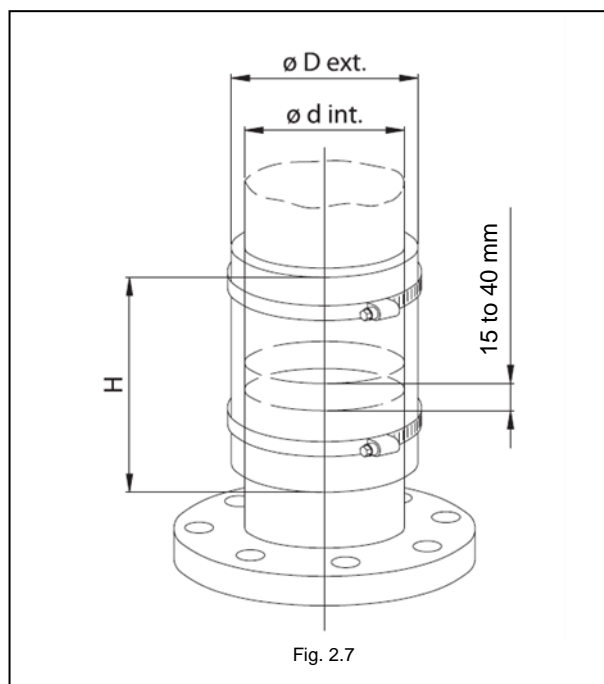



2.9.3 EXPANSION JOINT

For working temperatures of up to 110°, the expansion compensator is made of reinforced rubber with an omega section; for higher temperatures, the use of a stainless steel compensator is preferred. (See Fig. 2.8)

It is for connecting the ports of the machine to pipes and/or flanged fittings.

The compensator enables thermal expansion to be absorbed and prevents the transmission of vibrations from and to the machine. The fittings and the pipes linked above the compensator must be appropriately fixed so that they do not rest on the joint itself.

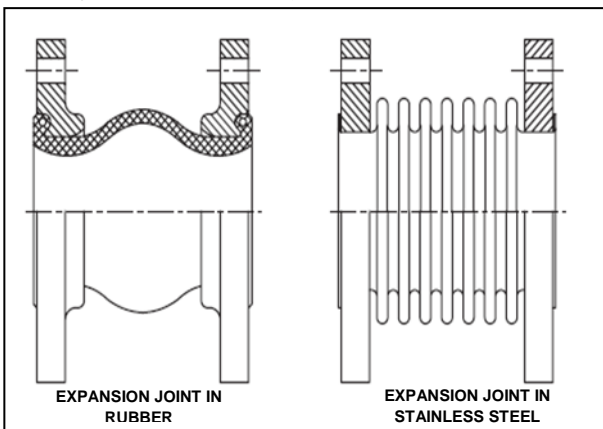

Fig. 2.8

2.9.4 BUTTERFLY VALVES

The CONTINENTAL compressors can be provided with manually, pneumatically or electrically operated butterfly valves.

Specific instructions are provided separately if required.

2.9.4.1 Butterfly valves - manual operation

A butterfly valve is generally found in all installations to cut the machine off from the system and/or to control its operation.

In most installations, it is preferable to fit the valve directly on the inlet opening. The §2.2 provides details about regulation of performance.

Generally, valves have an operating lever lock system.

2.9.4.2 Butterfly valve - pneumatic operation

This valve has the same function as that described in item 2.9.4.1 but is operated by compressed air.

It can also be used as an overflow valve in anti-surge systems.

Valves intended for on-off operation generally have servocontrols with a double-acting cylinder powered by a solenoid valve.

The compressed air supplied must have a pressure between 5 and 6 bars and must be filtered.

Operating speed can be controlled directly using the throttles on solenoid valve discharges.

There may be adjustable mechanical limits for fixing the maximum open and/or maximum closed positions of the butterfly.

There may be SPDT end-of-run contacts, which can be positioned with mechanical limits, for use in the startup sequence or for other controls and/or signals.

In addition to the compressed air supply, these also require an adjustment signal, range 3 - 15 psi (0.2 - 1 bar).

There are also pneumatic drives which require electrical regulation signals, range 4 - 20 mA or 0 to 20 V.

Where necessary, specific instructions are provided separately.

2.9.4.3 Butterfly valve - electrical operation

This valve has the same function as that described in item 2.9.4.1 but is operated using an electric motor.

It can also be used as an overflow valve in anti-surge systems.

Its operating speed is fixed.

The maximum open and maximum closed positions can be controlled using two limit switches.

The valve is suitable both for on-off operation and for regulation. Naturally, where used for regulation, the signal from the system must be processed by a suitable electric circuit.

When necessary, specific instructions are provided separately.

2.9.5 CHECK VALVE

A very common check valve comprises a disc fixed to the body at a single point on its circumference.

This must always be fitted with a vertical axis and so as to remain normally closed due to the effect of the force of gravity alone. Therefore, this valve must always be fitted on the process side of both blowers and exhausters. (Fig. 2.9)





Another type of check valve comprises two flaps fitted diametrically on to the body and loaded with two springs which keep them closed in any position.

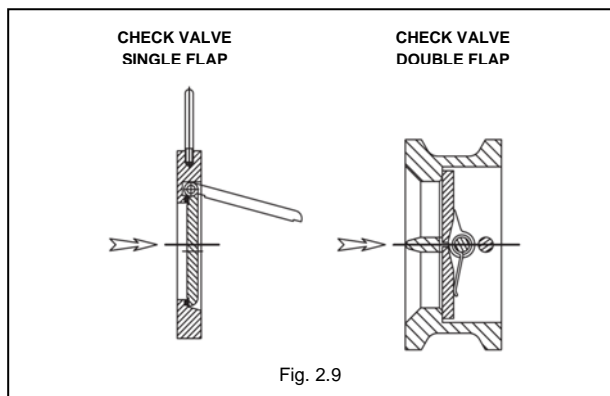

2.9.6 ANTI-SURGE VALVE

Where the fluid processed is air and where system characteristics so allow, the anti-surge valve can be used to prevent the machine operating at capacities lower than the minimum admissible, to prevent surge coming into operation.

In blowers, the valve must be fitted immediately down line from the outlet opening to allow air to be discharged into the atmosphere.

IMPORTANT:

In some cases, the efficiency of the antisurge valve can be impeded by the operation of the cutoff/regulation butterfly valve fitted at the machine inlet.

The anti-surge valve prevents the machine operating at positive/negative pressures greater than the design pressure and thus prevents the capacity falling correspondingly. The valve must be calibrated in the field.

Calibration is carried out as follows:

1. Start up the system and run at its nominal capacity
2. Gradually reduce the capacity so that it starts surging (surging is identified by a characteristic pulsing noise and can be confirmed by the movement of the needle of an ammeter connected to the machine's electric motor)
3. Use the tare nut of the valve spring to obtain sufficient opening to start surging
4. Continue alternating between reducing the capacity and adjusting the tension of the spring until the surging stops.

2.9.7 ANTI-SURGE CIRCUIT

Where the specific characteristics of the system (for example, operation at constant pressure) do not allow the use of the anti-surge valve described in item 2.9.6, an anti-surge circuit can be used.

A valve, permitting passage of the minimum flow of the compressor, is automatically controlled by a dedicated circuit.

Some anti-surge circuits operate on the basis of current absorption from the electric motor.

An anti-surge circuit is also often used in the start-up sequence of the bigger machines.

When necessary, specific instructions are provided separately.

2.9.8 INLET FILTERING

The inlet filter is for use with air. The standard filter comprises a flanged body which has a structure for supporting and fixing the filtering elements.

Depending on the nature of the pollutant, it is possible to clean the cartridge with varying degrees of ease. Clean as normal with a jet of compressed air or wash in water with detergent and rinse thoroughly. It is important to wait until the cartridge is perfectly dry before re-using it.

Filtering elements need to be cleaned or replaced when their pressure drop reaches a value of 30 to 50 mm H₂O. The inlet filter can be fitted with a protective cover for installation in the open air. The cover must be removed for maintenance. The filter silencer has a sound-absorbent cover which must be removed for maintenance. Inlet filters must be fitted where there is easy access for inspection and maintenance. It may be necessary to provide appropriate service platforms. For non-standard inlet filters, specific instructions are provided separately where necessary.

2.9.9 SILENCER

IMPORTANT: to indicate the flow direction, a mark "S" is written onto the downstream part of the silencer,

The inlet and outlet openings are the main sources of noise in the machine. The purpose of the silencer is to attenuate the propagation of that noise into the atmosphere.





The low pressure drop absorption silencers, full-flow or annular, are generally used:

- Onto the anti-surge pipe
- At the Inlet for a blower
- At the outlet for an exhauster

All silencers must generally be isolated from the machine by expansion joints or flexible sleeves and must be fixed with suitable brackets. They must be fitted as close as possible to the respective openings of the machine.

2.9.10 INSTRUMENTATION

Blowers and exhausters can be connected to instruments to display some of the operating parameters and also provide signals used for regulation, alarms and cut-off in case of break down.

2.9.10.1 **Ammeter**

This is installed mainly to have an approximate indication of the capacity of the machine driven by the electric motor.

The change in the current absorbed by the electric motor is directly proportional to the capacity handled by the machine. Using any minimum and maximum adjustable contacts in the ammeter, it is possible to obtain signals at surge limit and maximum load operation. These signals can be used in alarm and cut-off or regulation circuits.

To prevent damage to the instrument, the ammeter must be shunted during the start-up mode.

2.9.10.2 **Flowmeter**

In some processes, it is necessary to have an accurate measurement of the volume processed by the machine in order to regulate its performance.

Volume measurements are generally obtained from the value of the differential pressure generated via Pitot tubes (Annubar), Venturi tubes or calibrated diaphragms.

2.9.10.3 **Pressure gauge**

The pressure gauge can be used to determine the value of pressure generated by a blower. If it is fitted in a direction perpendicular to the one of the flow:

- Just downstream to the outlet opening, it provides the static outlet value of the load feeding the system.
- Just upstream to the inlet opening, it provides the static inlet value which, if it is a gauge measurement, is, for an exhauster, equal to the useable depression.

2.9.10.4 **Pressure regulator**

In some processes, it is necessary to keep the supply pressure constant.

This is generally regulated using a pressure transmitter, the signals from which are processed and possibly compensated by an appropriate pneumatic, electronic or mixed circuit.

2.9.10.5 **Thermometer - Thermostat**

The flow temperature can be monitored continuously through a thermometer or a thermostat: alarm or cut-off, if limit values are exceeded.

2.9.10.6 **Pressure switch**

Electric pressure switch is most commonly used in alarm and cut-off circuits for low pressure of lubricating oil of gearbox.

2.10 **SAFETY DEVICES**

2.10.1 BEARING TEMPERATURE

If required, CONTINENTAL blowers and exhausters can be equipped with temperature probes for monitoring the temperature of the two bearings. These probes are connected to a suitable electric alarm and/or shut-off circuit. The probes are fitted in the threaded holes provided in the housings

The threshold values of alarm and shut-off for the bearing temperatures are:

T alarm = 120°C and T cut-off = 140°C

The correct operation of the temperature probes must be checked regularly and, in particular, during start-up.

With the exception of water-cooled bearings, an increase of the temperature of a bearing above the normal limit is, in almost all cases, due to inadequate lubrication and occurs so suddenly that it is impossible to use any way to limit the damage.

The presence of an adequate quantity of lubricant must be ensured by regular preventive maintenance.

2.10.2 VIBRATIONS

The installation of a fixed vibration sensor at each bearing allowing a continuous monitoring avoids regular readings with portable devices.

The threshold values of alarm and shut-off for the bearing vibrations are:

Ve alarm = 5 mm/s RMS and Ve cut-off = 7 mm/s RMS

The correct operation of the vibration probes must be checked regularly and in particular during start-up.





3. RECEIPT, STORAGE, AND INSTALLATION OF THE MACHINE

3.1 MACHINE RECEIPT

3.1.1 PRELIMINARY CONTROLS

When machinery is taken directly from the workshop or from a carrier's depot or when it is delivered by a carrier, the delivery and/or dispatch documents must first be checked to ensure that the equipment ordered has been received. All packs comprising the supply, unless otherwise specified when ordering, are marked with the customer order number.

The packaging or the equipment itself must be checked for any obvious signs of damage incurred during handling or transport. If such damage is found, delivery reservations must be addressed directly to the carrier. Ensure that is clearly mentioned reservations on the delivery note before signing it. CONTINENTAL must also be informed promptly about, to avoid any disagreement and to guarantee rapid and satisfactory settlement of any damages.

3.1.2 UNLOADING AND HANDLING

The addressee is responsible and in charge of unloading operations and therefore, shall manage them in the best conditions, according to the size of the machinery and the difficulty presented by the operation.

3.1.3 CHECKS

A check shall be made quickly, that all the equipment received corresponds to the order. Any irregularities shall immediately be advised to CONTINENTAL for the

necessary corrective action. It is particularly recommended:

- to check all the accessories ordered and, eventually, the supply voltage of any electric motors
- to check that the data on the nameplate are in conformity with the order, in particular those related to ATEX certification

3.1.4 RECOMMENDATIONS FOR LIFTING

Due the large quantity of models produced by CONTINENTAL and the special features possible for each individual order, the handling shall be done by qualified people.

When handling by using cranes or overhead travelling cranes, the slings should be hung only to the rings destined for this purpose. (Fig. 3.10 – Example of advised handling)

Never use bearing housings for the lifting and the handling (except for model 008 to 051A).

Check that the connection between the CONTINENTAL blower or exhauster and the system of lifting presents all necessary safety. Check the position of the centre of gravity, not turn over nor rock. Not station under the load.

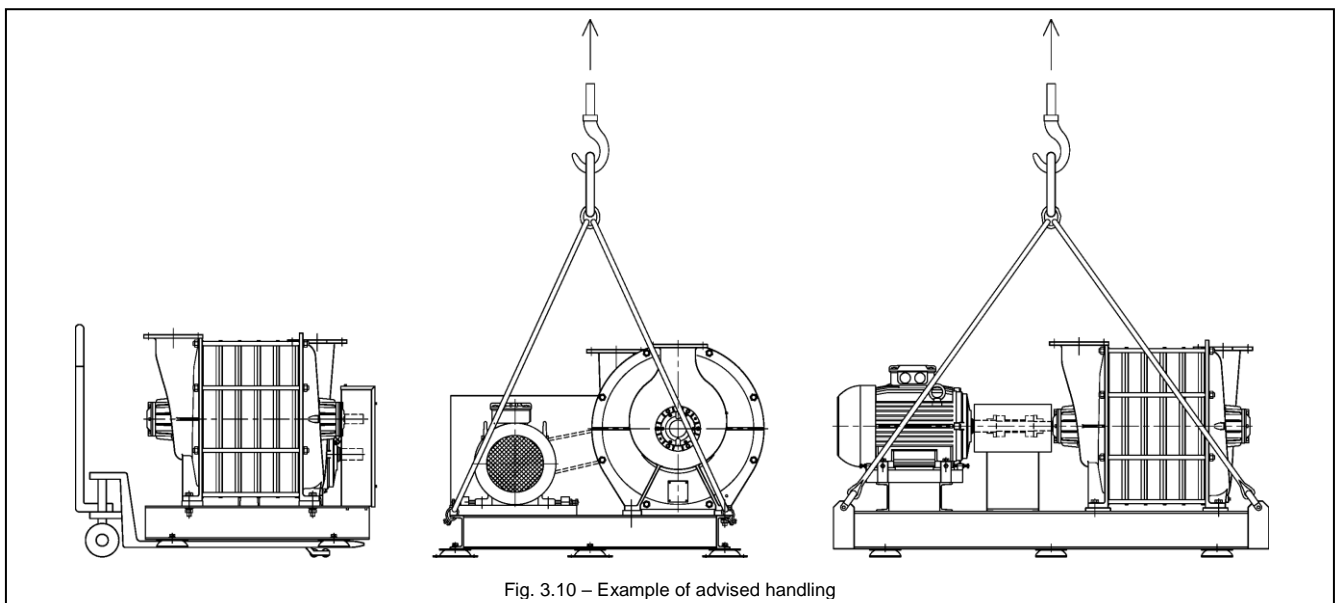

Fig. 3.10 – Example of advised handling





3.2 MACHINE STORAGE

3.2.1 SHORT TERM STORAGE

No particular storage precautions are required, when a period of machine inactivity is planned as not more than 60 days. The protections, foreseen before its dispatch from the workshop CONTINENTAL, are thus sufficient, if the considering machine and all additional parts (spare, reserve,...) is:

- in a clean and dry environment (RH < 70%)
- sheltered from vibrations and shocks
- with the covers on the inlet and outlet openings

3.2.2 LONG TERM STORAGE

For inactivity periods over 60 days, in addition to the recommendations of the § 3.2.1, the below precautions must be followed:

- Check the inlet and outlet openings are properly sealed
- Slacken any transmission belts
- Fill any oil-lubricated bearing housing in accordance with the instructions given in § 5.2.1.2
- Frequently check the condition of machined and unpainted surfaces (shaft ends, fulcrum, etc.) and add, when necessary, the protective coating provided by the factory.
- Approximately every 30 days, rotate the machine and motor shafts manually for a few revolutions.

During storage, it is essential to prevent the machine being subject to vibrations produced by the operation of nearby machines and propagated via the bearing surfaces. Such vibrations applied for long periods could damage the machine and motor bearings.

If there is a doubt about grease ageing, contact CONTINENTAL to eventually replace it.

It is also necessary to prevent the machine from being subject to frequent or sudden changes in temperature causing the formation of condensation, especially inside machines and motors and inside bearing housings.

When the possibility of condensation can be foreseen, the following shall be carried out:

- Hang, in an accessible way, a well-sized bag of a hygroscopic substance (example: silica gel) inside the inlet opening and inside the outlet opening, immediately replacing the respective protective sealing.
- Place a well-sized bag of a hygroscopic substance at the opening of each bearing housing.

- Isolate the equipment from the ambient atmosphere, if possible by using impermeable bags or by using impermeable covers carefully placed to minimize air circulation.

The hygroscopic substance bags shall be removed before the use of the equipment.

3.3 INSTALLATION

Throughout the installation phases, the two machine flanges must be kept closed.

Before beginning the installation, the following items must be taken into account:

- 3.1.2 UNLOADING AND HANDLING
- 3.1.4 RECOMMENDATIONS FOR LIFTING
- 2.3.1 BASE PLATE
- 2.3.2.1 RESILIENT PADS
- 2.3.2.2 LEVELLING PLATES AND FIXING BOLTS

The CONTINENTAL blowers and exhausters must be assembled in the position of installation for which they were designed and arranged. Consult the dimensional drawing specific to the project.

3.3.1 INSTALLATION SITE CHARACTERISTICS

CONTINENTAL blowers and exhausters, provided that they are intended for continuous operation, can be installed in the open air at almost any latitude.

If the equipment must be installed at ambient temperatures higher than 40°C or lower than -20°C contact CONTINENTAL INDUSTRIE.

The site, where the CONTINENTAL blowers and exhausters will be erected, must be in compliance with the local standards, the national regulations and the safety requirements.

To preserve integrity of the equipment, it is advised:

- Install safe from any aggression of the environment (at least on its upper part)
- Don't expose the equipment to attack from surrounding process: exhausts of air or other fluids, vibrations, radiations...
- All the precautions must be taken to avoid any vertical fall of object on the equipment or any intake of object by fall.

If installed in a closed room, it is necessary to ensure sufficient ventilation, in particular making it possible to keep an ambient temperature lower than 40°C. Contact CONTINENTAL INDUSTRIE if that is not possible.





The machine must be installed in order to allow an easy access to facilitate the preventive and routine maintenance.

3.3.2 INLET CONDITIONS

In general, the air or the gas admitted in the blower or the exhauster must be at a temperature ranging between - 20°C and +40°C.

3.3.3 ADMISSIBLE STATIC STRESSES ON FLANGES

It is always advisable to support the weight of the piping and accessories (at inlet, outlet, and surge line) to avoid stress on the compressor.

Nevertheless inlet and outlet or discharge openings can tolerate static stresses of forces and moments, with reference to their centre of gravity. That loads must not exceed the values given in tables 3.1 and 3.2 and in

Fig. 3.2.

If flanges with horizontal axis are used, stress must be reduced to the maximum.

It is important to keep in mind that installation of piping and accessories must consider the dilatation due to the working (use of expansion joints required). If not correctly fitted, equipments and piping can produce far higher stresses than their weight.

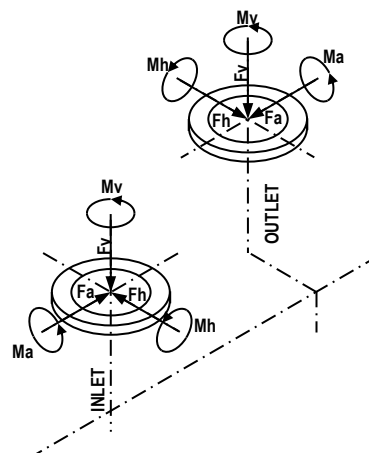

Fig. 3.2

Unit: daN	INLET			OUTLET		
MODEL	FV	FH	FA	FV	FH	FA
008	50	40	15	35	25	15
020	75	60	30	65	50	25
031A	75	60	30	75	60	30
051A	75	60	30	75	60	30
077A1	100	80	40	100	80	40
151A	150	120	60	150	120	60
251A	175	140	70	175	140	70
400A	225	180	90	175	140	70
451	200	160	85	200	150	80
500	225	180	90	200	160	80
600A	300	240	120	250	200	100
700	370	290	140	300	240	120

Tab. 3.1 – Admissible forces on vertical flanges

Unit: daN.m	INLET			OUTLET		
MODEL	Mv	Mh	Ma	Mv	Mh	Ma
008	15	15	30	9	9	18
020	22	22	45	18	18	36
031A	22	22	45	22	22	45
051A	22	22	45	22	22	45
077A1	30	30	60	30	30	60
151A	45	45	90	45	45	90
251A	52	52	105	52	52	105
400A	67	67	135	52	52	105
451	65	65	125	55	55	110
500	67	67	135	60	60	120
600A	90	90	180	75	75	150
700	105	105	230	90	90	180

Tab 3.2 – Admissible moments on vertical flanges





3.3.3.1 Accessories

Accessories installation, described into § 2.9, must deal with the previous load limits.

3.3.3.2 Piping

Piping must be accurately designed according to the nominal performances of the machine. An excessive pressure drop would significantly reduce performance.

Normally, piping is fitted after having definitely installed the machine in its final position.

Before erecting piping, it is essential to keep the machine covers. That prevents foreign bodies from getting into the machine during that phase. These covers must be removed before using the machine.

Respect the following advices for compressor connecting:

- If necessary, clean the inside of the inlet, outlet or surge piping, to avoid the penetration of any foreign object
- Check the inner cleanliness of any accessories
- Clean the cover on the openings using a damp cloth.
- Remove the cover and hygroscopic bags from the openings.
- Connect accessories and piping.

Piping must be erected with care and must be appropriately fixed to prevent excessive stress on the machine flanges, during mounting and operation.

The piping connected to the blower must be tight.

3.4 CONNECTIONS - UTILITIES

Once the machine has been installed and connected, the other connections required for its operation can be made.

The connection of the motor and other existing electrical components must be carried out on the corresponding electrical diagram, the indications given in the specific instructions notice of the motor and related particular electric components.

All the operations of electric connection must be carried out only by qualified personnel.

To prevent operations under voltage, the power supply components involved must be off and locked in this state with the displayed warning.

Check first the absence of voltage.

3.4.1 ELECTRICITY SUPPLY

The connection of the motor and other electrical components present must be carried out on the basis of

any electrical diagrams and instructions given in the following chapters:

- 1 General information
- 2.5 Motors
- 2.9 Accessories
- 2.9.10 Instrumentation

3.4.2 LUBRICATION SYSTEM

Where the machine has a separate system for the circulation, filtering and cooling of lubricating oil, for example where there are gearboxes for high power levels, specific instructions are provided separately.

3.4.3 WATER COOLING

Cooling water is required where heat exchangers are used to cool the lubricating oil and/or where there are cooled bearing housings. In these circumstances, the machine must be connected to the water supply and the drainage system.

The connection to the water supply system must have an isolating valve. An electric isolating valve can be used which allows water to circulate only to the machine in operation. For safety reasons, it is advisable to use an electric valve which is normally open or to fit the circuit with an alarm and cut-off system in case of breakdown.

The connection to the drains system must be such that it allows a direct view of the water drained. The capacity must be adjusted with a valve fitted up line from the exchanger or the housing so that it can be kept under pressure during operation.

4. START-UP

The instructions given below are generic and must be completed by the technician in charge of the start-up considering the installation specificity.

4.1 PREPARATION

To prepare the machine for start-up, the following must be carried out:

- To ensure that main piping is absolutely clear: no cover, valves open ...
- Refill the bearing housing oil as instructed in § 5.2.1.2.
- Direct transmission: during motor uncoupled, turn the shaft manually to check that it is not blocked, then mount the transmission element (according to manufacturer instructions)
- V-belt: Check alignment and tension of belts as instructed in § 5.2.2.2





4.2 CHECKS

Immediately prior to starting up the machine, make the following checks:

- Check that the baseplate of the machine has been installed as instructed in § 2.3.1 and 2.3.2.
- Check the compatibility of supply voltage of the electric motor and the other electrical equipments.
- Check the connection of the electric motor (§ 2.5.1) and other electrical equipments referring to the indications provided in the specific manuals.
- Check the installation of equipments and safety device, referring to the instructions given in § 2.9 and 2.10.
- Check that the inlet line has been fitted correctly and that all flanges are tight.
- Check that the outlet line has been fitted correctly and that all the flanges are tight.
- Check that the anti-surge line has been fitted correctly and that all the flanges are tight.
- Check that the screws anchoring the machine to the base plate are tight.
- Check that the screws anchoring the motor to the base plate are tight.
- Check that any screws and any transmission couplings have been correctly tightened.
- Check that any brackets and gauges used for alignment have been removed.
- Check that there is lubricating oil in the bearing housings and in any other oil-lubricated components.
- Check that all protective guards have been correctly fitted.
- Check the compatibility of the rotation sense of motor and compressor (to see the marking on the outlet head and eventually on motor fan guard).

4.3 VALVES MOUNTING AND SETTING

Refer to hereby drawing for the mounting of the valves. In particular, the following points shall be checked (Fig. 4.1):

- Shaft of the butterfly mounted perpendicular to the blower shaft.
- Lower part of the open valve towards the outside of the blower.

These instructions shall be carefully observed in order to ensure the correct process air flow operation of the unit.

Non observation of these instructions may void factory warranty.

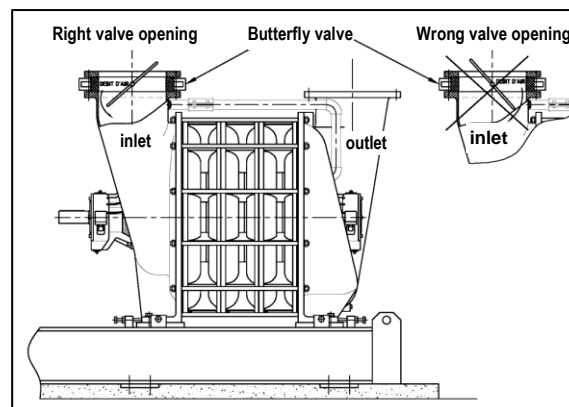

Fig. 4.1

All the valves must be checked:

- Manual and regulation valves for utilities must be adjusted.
- Isolation valves for any instruments used must be open.
- Valves assigned to the fluid process must be appropriately set for the following purposes:
 - Controlling the flow of the fluid processed depending on the specific requirements of the system served.
 - Minimize the start-up time.
 - Preventing the machine from surge operation (see § 2.2.1).





4.3.1 INLET VALVE

The degree to which the inlet valve is opened determines the compressor load (outlet valve opened).

To keep the start-up time as short as possible, the valve must be set to its minimum aperture. Excessive closing of the valve causes the machine to go into surge operation.

Small machines can be started up with the valve nearly closed.

Other machines must be started up with the inlet valve set for a capacity slightly greater than that the one foreseen for the surging. As this setting depends on the ambient temperatures, it can only be determined experimentally: the first start-up should be with an opening of 15°; that setting can be adjusted to optimize the start-up time.

4.3.2 ANTI-SURGE VALVE

If necessary, the opening of this valve should be limited to comply with the maximum load of the compressor.

4.3.3 OUTLET VALVE

This valve must be kept open during operation.

It is often used as an isolation valve. In the case where the network cannot receive the treated fluid, anti-pumping circuit must be used.

4.4 ROTATION DIRECTION

The compressor shaft must rotate as indicated by the arrow on the outlet head. The rotation direction of the complete unit can be inverted by switching 2 phases of the supply cable (that direction must be compatible with motor one).

4.5 COMMISSIONING

- Start up any pumps and compressors which ensure the circulation of any service fluids (lubricating oil, cooling water, compressed air etc.).
- Check that the control valves of the flow are not completely closed and ensure a sufficient air flow to avoid working in the surge zone.
- Start up the machine up to its nominal speed, paying particular attention to irregular noise or high levels of vibrations; if any doubt appears regarding working quality, stop the machine immediately and carry out the necessary checks before any new start-up.

- In the case of star/delta start-up check the start-up time to optimize timer regulation for commutation to delta.

- Check power absorption and correct as follows:

→ If power consumption is unstable, the machine is in surge operation and volume must be increased using the valve(s).

→ If power consumption is excessive, the volume needs to be reduced by closing the valve(s) or by reducing the speed (Variable Frequency Drive).

- Let the machine run for approximately 30 minutes, then check the vibration level and the temperatures (see § 2.10).

- If everything is normal, let the machine run for a further 30 minutes, then stop it and carry out the following operations:

- check the tension of the belts as instructed in § 5.2.2.2.

- check the alignment of transmission couplings when hot as instructed in § 5.2.3.

→ After carrying out all that steps the process check can be done.





5. BLOWERS AND EXHAUSTERS MAINTENANCE

The CONTINENTAL blowers and exhausters are delivered in perfect operating condition. To maintain the characteristics of the equipment and to ensure its high reliability, it is important to set up a plan of maintenance.

5.1 MAINTENANCE SCHEDULE

	SUBJECT	MAXIMUM INTERVAL (*)	REQUIRED ACTION	POSSIBLE CORRECTION	
			Record in the maintenance notebook	Correction on site	Replacement
Preventive maintenance	V-belts (§5.2.2) Replacement	2 years	X		
Maintenance - Repair	Visual check for oil in the oil feeder (§5.2.1.2)	1 week	X	X	
	Oil replacement (§5.2.1.2)	3 000 h (Heavy duty)	X		
		6 000 h (Light duty)			
	Bearings greasing (§5.2.1.1)	1 month (Heavy duty)	X		
		3 000 h (Light duty)			
	Direct drive: Fixation, alignment and general state (§5.2.3)	6 months	X	X	X
	V-belts drive: tension and V-belts wear, fixation, alignment and general state (§5.2.2)	1 week (for ATEX equipment)	X	X	X
	Machine integrity: - parts fixation - coating state and corrosion	6 months	X	X	X
Good operation of the safety devices (§2.10)	Everyday			X	
Operation monitoring	Bearings temperature level (§2.10.1)	1 month	X		
	Bearings vibration level (§2.10.2)	1 month	X		5.2.4 Ball bearing replacement
	Noise level (§6.2)	1 week	X		

Tab 5.1

(*) After a long period of stop (> 2 weeks) all the points must be checked





5.2 MAINTENANCE OPERATIONS

During routine maintenance schedule to keep the machine efficient, components subject to wear must be checked. Preventive maintenance planning prevents unexpected stop.

In addition to the normal lubrication operations to be carried out at pre-set intervals, it is asked to keep a report for each machine, about the progress over time of parameters which reflect how good the parts most commonly subject to wear are.

Continental recommends regular measurement of vibration levels for bearing housing. With a large record of values, the operator is able to better inform maintenance staff of replacement intervals.

5.2.1 LUBRICATION

5.2.1.1 GREASE LUBRICATION

The ball bearings lubrication is essential for the following reasons:

- to avoid metal-to-metal contact
- to protect the bearings from corrosion and wear

Lubricating greases are composed of mineral oils or synthetic fluids dispersed in a thickening agent which determines its consistency, normally assessed in accordance with the NLGI classification (National Lubricating Grease Institute). The consistency, the temperature range of use and the rust proofing properties are the main determining factors when choosing grease.

The operating characteristics of CONTINENTAL machines require a grease of grade 3 which can be used in the temperature range from -20°C to +140°C.

Sample of grease characteristics used with CONTINENTAL blowers and exhausters:

GREASE HP-ST 3		
Grade NLGI	3
Soap	Lithium
Color	Brown
Flash point	> 190°C
Aspect	smooth
Temperature range	-20°C/ +140°C

Equivalent grease:

ESSO	BEACON 3
MOBIL	MOBILUX EP3

Generally, lithium soap greases, with the addition of rust-proofing additives or EP (Extreme Pressure), are able to meet the above requirements.

Re-lubrication with greases of a different type is not recommended as this creates the risk of mixing incompatible greases with each other. Consistency and maximum admissible temperature values could, indeed, fall below the typical values required.

To ensure efficient lubrication, limit the grease volume to the volume strictly required.

If there is grease excess, the temperature of the bearing increases suddenly, that substantially reduces its service lifespan and can cause irreversible damage. In such conditions, the bearing operates at temperatures far higher than those of its design and is subjected to premature wear.

In practice, it is enough that the grease does not take up more than 30 - 50% of the free space in the housing; if the quantities in Tab 5.2 are respected, that requirement is achieved.

Type	Grease quantity per bearing (g)
008	5
020	5
031A	10
051A	10
077A1-151A	20

Tab 5.2

All bearings on CONTINENTAL INDUSTRIE machines are fitted with grease slingers to, automatically (when running):

- allow its circulation
- prevent its accumulation into the bearing housing
- avoid ball bearing overheating

However, some of the grease is consumed; it must be completed according to the periodicity defined in the Tab 5.1.





Light duty

When simultaneously:

- Rotation speed inferior or equal to 3600 rpm
- Clean and protected environment
- Outlet temperature inferior or equal to 100°C

Apart these conditions, a **heavy duty** can be suspected.

Heavy duty

If at least one of the following conditions is completed:

- Continuous operation (24h/7days) with tough atmosphere (humidity, dust, chemical aggression...)
- Installation outdoors
- Operation with high temperatures
- High rotation speed (6000 rpm on model type 008 to 020 and 4000 rpm for type 031A to 077A1)

The plug located at the bottom must be removed prior to the re-lubrication. **Do not forget replacing it after this operation.**

Bearings on CONTINENTAL machines are fitted with hydraulic greasers. Use a manual pump to re-lubricate.

NOTE:

The bearings are filled with grease at the CONTINENTAL factory for mechanical running tests; so there is no need to grease the machine before start up.

If the delay of three months from delivery date is exceeded repeat the re-lubrication according to Tab 5.2.

5.2.1.2 OIL LUBRICATION

Oil lubrication is used where the rotation speed or the operating temperature exceed the grease employability limit.

All oil-lubricated machines are fitted with a tank, directly mounted on the bearing housing. The oil level is maintained by a constant level oil feeder and an oil nozzle disc.

During operation, oil-lubricated machines produce actual oil circulation inside the housing. This oil circulation provides lubrication and cooling action on the bearing and immediately removes any pollutants which may affect it.

Particle pollutants of a magnetic nature are caught by the drain magnetic plug. Other pollutants deposit at the bottom of the tank. For the lubrication of ball bearings, mineral oils are generally used with the addition of additives, to improve both resistance to oxidation and the lubricating film adherence.

Viscosity is one of the main characteristics of lubricating oil. Viscosity decreases when the temperature rises. Therefore when choosing oil, it is essential to check that at the design maximum operating temperature, the

viscosity remains at values which enable a lubricating film of an adequate thickness.

Sample of oil characteristics used by CONTINENTAL blowers and exhausters:

JAROGEAR Z .150	
<u>Properties :</u>	
Extreme pressure, anti-oxidizing, anti-corrosive, anti-foam, anti-rust, high temperature resistance.	
Density at 15°C	0,892/0,917
<u>Cinematic viscosity in Cst:</u>	
at 40°C	143/148
at 100°C	14, 3/15,5
Viscosity index	103
Flash point VO	≥215°C
Flow point	≤ -24°C
<u>Other equivalent oils:</u>	
ESSO	SPARTAN EP 150
Q8	GOYA 150
TOTAL	CARTER EP 150
SHELL	OMALA S2 G 150

The level of use needs to be assessed by the maintenance personnel with reference to the following information:

Heavy duty

- continuous operation (24h/7d)
- operation with humidity, dust or chemical aggression atmosphere
- installation outdoors

Light-duty

- non-continuous operation (4hours/day or less) in a clean and protected environment

Also excessive lubrication causes temperature rise and reduces lifespan for bearings.

Housing refilling

The housing refilling must be done with precaution, machine stopped. Ensure that oil level does not exceed the one maintained by the action of the constant-level oil feeder.

We can make the correct filling by introducing the oil through opening corresponding to the plug 1 (see Fig. 5.3) until the level is reached, checked by a small leakage





through the opening corresponding to the plug 2. Then replace plugs 1 and 2 to add oil by oil feeder (as shown on Fig. 5.4) until the level stabilizes. The handling of the oil feeder must be done quickly to not destabilize the oil level inside the bearing.

To avoid incompatible oils mixing, we recommend using the same oil.

Bearing housings in CONTINENTAL machines are partly drained after mechanical testing to prevent oil leakage during transport. Therefore, the housings must be refilled as described.

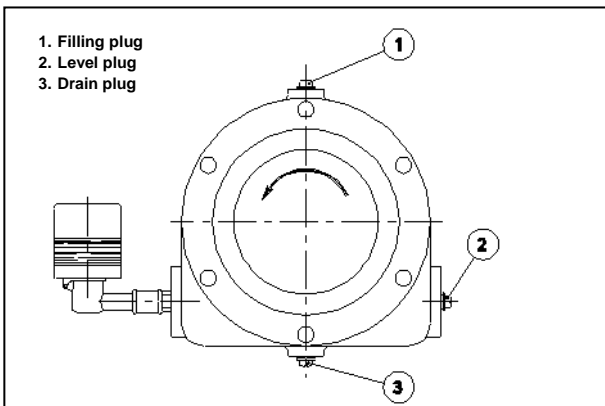

Fig. 5.3

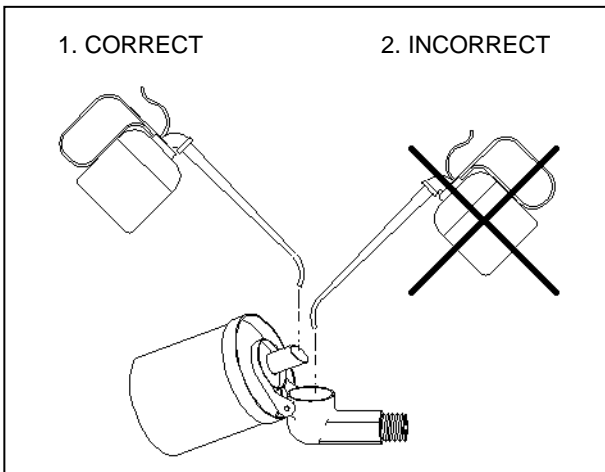

Fig. 5.4

The quantities of oil required for filling, depending on the machine model, are shown in table Tab. 5.5 hereafter.

CAPACITY OF OIL-LUBRICATED MACHINES (liters)

MODEL	PER HOUSING	PER OILER	TOTAL PER MACHINE
077A1	0.56 or 1.56	0.11	1.34 or 3.34
151A	0.56 or 1.56	0.11	1.34 or 3.34
251A / 400A / 451 / 500	1.8	0.11	3.82
600A / 700	5	0.11	10.22

Tab. 5.5

Filling oil feeder

The oil feeder is a reserve of oil to keep the oil level constant in the housing bearing. **It is not a visual indicator of oil level.**

It is not necessary to add oil to the oil feeder until it is empty.

Some precautions has to be followed to renew this reserve:

1. Swing quickly the oil feeder
2. Observe Fig. 5.4

At the first start, a relatively quick decrease of the oil inside the glass may occur. Stabilization is achieved after a few hours of operation

5.2.2 V-BELTS DRIVE

5.2.2.1 V-belts replacement

This operation must be considered in the case of the visible deterioration of one or more belts and, at the latest, every two years.

The replacement of transmission belts is a rare maintenance operation during the first 2 years of operation if the following conditions are maintained:

- Minimum tension but enough to ensure minimum slipping
- Pulleys alignment according to § 5.2.2.2

The operation of the blower or the exhauster, above the maximum capacity authorized by the belts, is prohibited. It is recommended to avoid frequent starts, because they significantly decrease the lifespan of the belts.

It is recommended to check belt tension regularly and to correct it if necessary, ensuring that pulley alignment is observed. This verification must be done frequently during the first hours of operating.





To replace the belts, the protective guard has to be removed, and the motor/machine centre distances reduced, by using the motor fixing screws and those provided for its positioning.

On the opposite, the machine position relative to its base-plate must not be changed in any way.

It is very important that each belt transmits its part of power: the transfer of required power needs all the belts. In the opposite case, all the power is transmitted by only some of the belts which, as they are overloaded, wear prematurely.

To avoid that, the pulleys must be well-aligned. It is essential that all the belts are identical: it is necessary that belts are come from the same production batch.

→ Therefore, the belts should not be replaced separately, but the complete set must be replaced.

When the belts are bought, it is preferable to order belts by sets rather than a given number of belts.

Before the belts replacement, its cause must be determined: normal wear or other reasons? In that last case, dysfunctions which produce premature wear must be located and eliminated.

Once the set of belts replaced, it is necessary to proceed to the alignment and the tension of the belts (§5.2.2.2).

5.2.2.2 V-belts transmission alignment

The alignment of the pulleys and the correct tension of the belts guaranties maximum lifespan of the ball bearings and the belts themselves.

The external faces of the 2 pulleys must be on the same vertical plane and that is generally carried out by placing a straight iron bar as shown in Fig. 5.6.

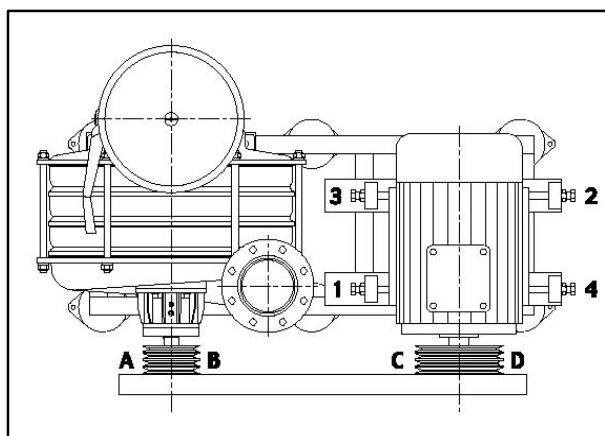

Fig. 5.6

The face of the machine pulley is taken as a reference (Point A and B) and the bar is placed on it, checking contact points C and D.

If the faces aren't parallel, a correction is necessary by using the adjustment screws 1, 2, 3 and 4.

Note that:

- Adjust belt tension via screw 1
- Correct angle between pulleys via screw 2
- Use screw 3 and 4 for blocking position

Method:

1. Loose slightly motor fixing screws to allow motor moving
2. Loose screws 3 and 4 and then 2
3. Adjust belt tension by using screw 1. Turn motor pulley manually to distribute tension equally
4. Adjust parallelism via screw 2
5. To align the pulleys planes, it can be necessary to move the motor pulley: to allow the pulley hub axial motion, loose its hub screws.
6. Use the iron bar to check that the points A, B, C and D are in contact. Adjust if necessary via screw 1 and 2.
7. When parallelism and alignment are correct, tighten the four motor screws.
8. Tighten screw 3 and 4 to contact.
9. Block the locknuts of screws 1, 2, 3 and 4
10. Finish the tightening of motor pulley hub screws
11. check the belts tension

Always carry out alignment when setting and adjusting the belt tension.

Carry out alignment and tension setting until you obtain in the same time the desired alignment and tension.

ATTENTION, alignment operation is critic:

Misalignment:

- causes asymmetric wear of the belts
- makes the load not uniformly distributed on the belts
- results, so, in a premature change of the complete belts set

Excessive belt tension increases:

- load on the ball bearings
- bending torque of the shaft
- the risk of shaft break due to fatigue

Low belt tension causes





- slipping
- overheating (by friction)
- premature wear
- irreversible damages (pulleys included)

5.2.2.3 V-belts tension

Specific data to set correctly belt tension is necessary.

Fmin and Fmax are the values between the F force must be. When applied in the middle of the two axes on a single belt and perpendicular to it, as shown below, is produces a deflection equal to f mm.

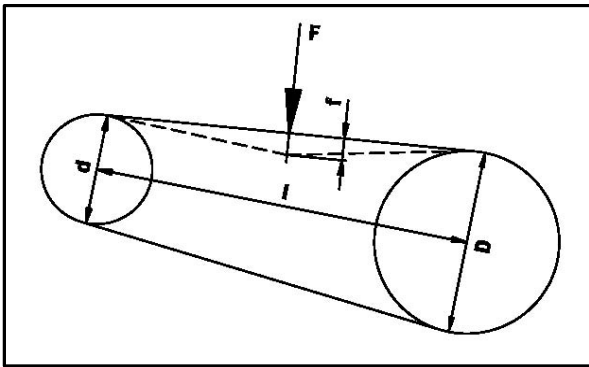

Fig. 5.7

MODEL 008		Deflection (f) (in mm)	Force (in daN)	
			Fmin	Fmax
P	4 kW	5	1.0	1.5
	7.5 kW		1.0	1.5
	11 kW		1.5	2.0
	15 kW	1.5	2.0	
	18.5 kW	1.5	2.0	

MODEL 020		Deflection (f) (in mm)	Force (in daN)	
			Fmin	Fmax
P	4 kW	5	1.0	1.5
	7.5 kW		1.0	1.5
	11 kW		1.5	2.0
	15 kW	6	1.5	2.0
	22 kW		1.5	2.0
	30 kW		1.5	2.0
	37 kW		1.5	2.0

MODEL 031A/051A		Deflection (f) (in mm)	Force (in daN)	
			Fmin	Fmax
P	11 kW	8	1.5	2.0
	15 kW		1.5	2.0
	22 kW		1.5	2.0
	30 kW		1.5	2.0
	37 kW		2.0	3.0
	45 kW		2.5	3.0
	55 kW		2.5	3.0
	75 kW		3.0	4.0
MODEL 077A1		Deflection (f) (in mm)	Force (in daN)	
			Fmin	Fmax
P	15 kW	9	1.5	2.0
	30 kW		1.5	2.0
	37 kW		2.0	2.5
	45 kW		2.0	2.5
	55 kW		2.5	3.0
	75 kW		2.5	3.5
	90 kW		2.5	3.5
	110 kW		2.5	3.5
	132 kW		3.5	4.0

MODEL 151A		Deflection (f) (in mm)	Force (in daN)	
			Fmin	Fmax
P	15 kW	11	1.2	2.0
	37 kW		2.0	2.5
	45 kW		2.0	2.5
	55 kW		2.5	3.5
	75 kW		2.5	3.5
	90 kW		3.0	4.0
	120 kW		3.0	4.0
	132 kW		3.0	4.0

If the belts are new, Fmin and Fmax need to be increased by 30% to take into account the rapid fall in tension occurring during the running-in period.

Tensioning is checked after the first 4 hours of operation.

5.2.3 COUPLING ALIGNMENT

This operation must be carried out for the first start-up and after each displacement of the compressor or the motor.

The correct alignment of the transmission coupling minimizes vibration during operation and ensures the maximum lifespan of the ball bearings.

Before carrying out that operation, it is essential to read the §2.3.3.1, Direct transmission.





The alignment allows to:

- Place the axes of the two shafts coupled on the same vertical plane or on two parallel vertical planes, with a specified distance between them.
- Place the axes of the two shafts coupled on the same horizontal plane or on two parallel horizontal planes, with a specified distance between them.
- Keep a specified distance between the ends of the two coupled shafts, or better, between the two faces of the half couplings.

Radial misalignment and angular misalignment are shown in Fig. 5.8. Naturally, these can be present together.

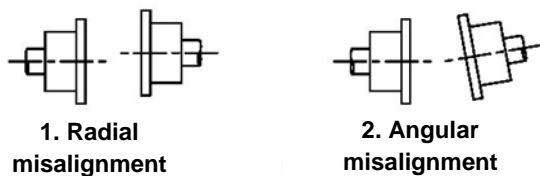

Fig. 5.8

Due to the thermal expansion, the relative position of the two shafts coupled varies from the cold start up ("cold") and the steady state operation ("hot").

The final alignment must be the hot in steady state operation ("hot").

From cold alignment, a compensation of compressor dilatation is generally necessary.

Maximum admissible misalignment when hot can vary depending on the type of coupling; however, if no specific instructions are given, the following tolerances must be used:

distance between the half coupling faces	180 mm (+0,5 mm / -0)
radial misalignment (T.I.R.)	0,05 mm
angular misalignment	0,02 mm (for \varnothing 100 mm)

We recommend using a laser measurement tool to carry out alignment.

The distance between the half coupling faces where there is a spacer can be measured by means of a caliper or an internal micrometer or otherwise by a thickness gauge.

Radial mis-alignment can be assessed by means of a set square or a straight bar which is sufficiently rigid and long, but it is preferable to use a gauge fitted as shown in Fig. 5.9 A.

The T.I.R. reading (Total Indicator Reading) given by the gauge for a 180° rotation represents double the actual misalignment. With reference to Fig. 5.10, half of the reading for a 180° rotation from 0° to 180° provides the height difference between the shaft axes. Half the reading for a 180° rotation from 90° to 270° provides the distance between the two vertical planes on which the shaft axes are placed.

Angular mis-alignment can be assessed by means of a caliper, internal micrometer or a thickness gauge, but it is preferable to use a gauge fitted as shown in Fig. 5.9 B.

The ratio between the T.I.R. reading (Total Indicator Reading) provided by the gauge for a 180° rotation and the diameter of the circle described by the rotation of the tracer point axis represents the tangent of the misalignment angle.

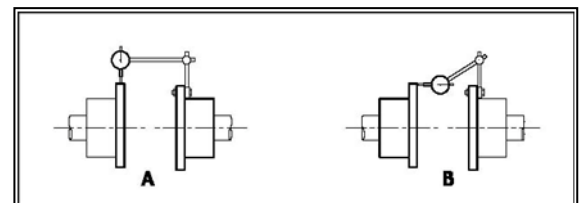

Fig. 5.9

With reference to Fig. 5.10, from the reading for a 180° rotation from 0° to 180°, the angular mis-alignment is determined by the height of the couplings. From the reading for a 180° rotation from 90° to 270°, the angular mis-alignment is determined by the transversal position of the couplings.

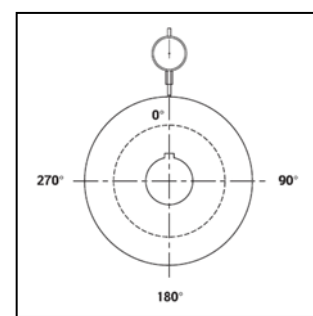

Fig. 5.10

Machines and/or motors are moved laterally by means of appropriate adjustment screws provided in the works. A lead mallet may be needed for smaller machines without adjustment screws.

Machines and/or motors are moved vertically by using shims placed under the feet as required. When adjusting





the height of machines and/or motors with shims, the following precautions are recommended:

- Ensure that the feet, their bearing surfaces and every individual shim used are as clean as possible
- Ensure that all the anchoring screws have been tightened before taking the readings
- Ensure that all the feet are completely in contact with the shims and that the tightening of the anchoring screws does not produce any deformation to the baseplate and/or the machine or motor.

→ A good practical method for alignment is as follows:

1. study the machine, the height and position of which needs to be considered fixed with regard to the baseplate
2. Check that its anchoring screws are centred in the holes, i.e. that it is possible to move it in all directions
3. Completely tighten the anchoring screws
4. Check that the height of the shaft is greater than or equal to the minimum required, correcting with shims if necessary
5. Place a gauge with a magnetic base on the base-plate and a tracer point on the machine feet close to one of the anchoring screws and set it to zero
6. Slacken the anchoring screws and check that the gauge does not indicate movements of more than 0.005 mm (any movement greater than the given value requires the insertion of corrective shims)
7. Repeat the operation for all the anchoring points to the base-plate
8. Slacken the anchoring screws of the other machine
9. Measure the distance between the faces of the two half couplings and move the machine in an axial direction until the prescribed value is reached
10. Tighten the anchoring screws
11. While rotating the two half couplings at the same time measure the radial mis-alignment and:
 - Move the machine transversally until the prescribed value is obtained (T.I.R. 90° - 270°)
 - Shim all the machine feet until the prescribed value is obtained (T.I.R. 0 - 180°)
12. while rotating the two half couplings at the same time measure the angular mis-alignment and:
 - Move the machine transversally until the prescribed value is obtained (T.I.R. 90° - 270°);
 - Shim two of the feet of the machine until it comes within the prescribed tolerance (T.I.R. 0° - 180°)

Operations 11 and 12 affect each other reciprocally and therefore must be repeated alternately until the correct result is obtained.

13. Repeat on this machine the operations described in items 5, 6 and 7.

5.2.4 BALL BEARING REPLACEMENT

When one ball bearing becomes too noisy or the vibrations level makes fear a nearest rupture, the two ball bearings replacement must be considered.

A bearing dismounted must be never reassembly. It must be replaced by a new one.

In the case of sudden breakage, the repair operation can involve far more than a simple replacement of the ball bearing, and, in some cases, can even involve the replacement of the rotor.

Regular maintenance of the equipment (§5.1) decreases considerably the risk of rupture of the ball bearing.

Lack of lubrication

In particular, the total lack of lubrication, due for example to an excessive quantity of grease as described in item 5.2.1, can cause the internal ring of the bearing to weld on to the shaft, which then needs to be replaced.

Noisy bearing

Where, on the other hand, a bearing is replaced because its noise level and/or vibration level has increased on the housing, indicating that it may break in the near future, the operation can be carried out much more simply and rapidly.

Drive side bearing

In the case of the coupling end bearing, the pulley or coupling must be removed.

Pulley with friction connectors

Pulleys with friction connectors can be removed and refitted quite easily without the use of extractors. It is, however, advisable to mark their position with regard to the shaft before removing them.

Traditional pulleys and half couplings

For traditional pulleys and for half couplings, on the other hand, an extractor must be used.

Where possible, threaded holes are provided in the hub of the pulley or the half coupling so that hydraulic jacks can be used.

Traditional pulleys and couplings can be heated in an oil bath for ease of refitting.

Direct transmission

Machines with direct transmission are sometimes fitted with a coupling with a spacer which allows the coupling end bearing to be replaced without disturbing the alignment.





DISMOUNTING PROTOCOLE

1. For oil-lubricated bearings, the housing must be drained before it is removed.
2. With the housing cover removed, dismantle the various components (lock nut, spacers, discs etc.) until the bearing inner ring is released. It is important to note the dismantling sequence of all the components to be sure of refitting them in the same position and in the same direction.
3. Then remove all the screws fixing the housing to the head and, using the two threaded holes provided on the housing connection flange and screws of a suitable length, the bearing is removed using the housing itself as an extractor.

Important:

The bearing extracted in this way cannot be re-used as the rolling bodies and tracks have been stressed.

4. Before continuing, all the components to be refitted must be carefully cleaned and inspected. This is an opportune moment to inspect and, if necessary, replace the sealing rings on the shaft as they are accessible with the housing removed.
5. The housing can then be refitted with all the fixing screws thoroughly tightened.
6. The new bearing shall be removed from its packaging at the latest possible moment to avoid any extraneous matter entering it. **Obviously, pre-lubricated bearings with shields must not be washed and it is sufficient to remove the protective film from the internal and external rings.**
7. Before fitting the new bearing, it is a good idea to oil lightly the seats on the shaft and in the housing, to improve their glide.
8. In the installation phase, pressure must never be applied to one ring to make the other one slide, as this will certainly damage the rolling bodies and the tracks.
9. The force necessary to overcome friction generated at the same time at the internal and the external rings, must be applied at the same time to the two rings by means of a very thick ring which has an external diameter slightly less than the diameter of the external ring and an internal diameter slightly greater than that of the internal ring. The force via the ring can be applied using a hydraulic cylinder appropriately connected or by hitting with a lead mallet.

Under no circumstances are the rings, cage or rolling bodies to be hit directly.

10. It is essential to check that the internal ring of the bearing is tightly fitted before the other components are fitted. It is worthwhile noting that the outlet end bearing is left axially free to absorb the thermal expansion difference between the shaft and the body of the machine and therefore its external ring can slide axially in the housing within certain limits and does not come into contact with the housing end cover.
11. The inlet end bearing, on the other hand, is connected axially and defines the position of the whole rotor with regard to the body of the machine. Its internal ring is clearly tightly fitted to the shaft and the position of the external ring is defined on the one hand by the housing support and on the other by the housing cover. A ring with a calibrated spacer is sometimes fitted between the housing cover and the bearing external ring.
12. When the inlet end bearing is replaced, it may be found that the shaft slides axially, returning, however, to its original position once the operation is completed.
13. It is possible to check that the bearing replacement operation has been carried out correctly by checking that the rotor of the unit rotates freely manually and is restrained axially in both directions.

Before unit restart, it is important to check the following items:

- 5.2.1 Lubrication
- 5.2.2.2 V-belts transmission alignment
- 5.2.3 Coupling Alignment
- 5.2.2.3 V-belts tension

When the unit is brought into operation, it is essential to check that the level of vibrations on the housing and the bearing temperature, measured on the external ring via the appropriate hole, lie within normal values.





5.3 SPARE PARTS

CONTINENTAL blowers and exhausters can operate for extremely long periods before spare parts are needed. It is advised to keep a stock of the recommended set of spare parts.

5.3.1 RECOMMENDED LIST

Spare parts for any particular components and/or equipments must be provided in addition:

- bearing cover gasket
- bearing lock nut
- bearing lock washer
- ball bearing
- bearing housing gasket (if present)
- Graphite or carbon ring housing gasket (if present)
- Graphite or carbon ring (if present)
- oil or grease feeder (if present)
- set of transmission belts (if present)

5.3.2 CONSUMABLES

They are restricted to:

- filter cartridges (if present)
- lubricant

5.3.3 ORDER

The reference number of the spare parts can be found on the sectional drawing of the machine and eventually on the corresponding components list.

When ordering spare parts, it is asked to give the serial number of the machine.

All spare parts must be ordered to:

CONTINENTAL INDUSTRIE
Route de Baneins
01990 Saint Trivier sur Moignans, FRANCE

TEL.: + 33 (0)4 74 55 88 77
FAX: + 33 (0)4 74 55 86 04
Email: export@continental-industrie.com

6.1 PERFORMANCES REDUCING

These can occur through a flow and consecutive differential pressure reduction, or by a significant variation of consumed power.

POSSIBLE CAUSE	RECOMMENDED REMEDY (INDICATIVE)
Inlet filter clogged	➡ Replace filter elements
Upstream or downstream valves not correctly adjusted	➡ Check and correct §4.3
Upstream or downstream pipe clogged	➡ Check and clean if needed (internal zone must be unchanged)
Direction of rotation reversed following maintenance operations on the motor or electrical equipment	➡ Check and correct §4.4
Rotation speed lower than nominal (motor with VFD)	➡ Check and correct
Partial blocking of the impellers or intermediate sections (presence of clogging elements in the processed fluid)	➡ General overhaul of the machine. Consult CONTINENTAL INDUSTRIE

6. TROUBLE SHOOTING

CONTINENTAL blowers and exhausters are designed for keeping their performances unchanged over time. The efficiency, the noise level and the operating temperatures remain at their initial values.

As soon as appears a doubt about the capacity of the equipment to ensure a total safety, it must be put immediately out of service and locked in off position.





6.2 NOISE PRESSURE LEVEL VARIATION

The sound pressure level cannot exceed a lot the value obtained during the first start-up.

The noise level emitted by the machine with its accessories is generally lower than 95 dB (A). The variations of the noise level produced by the equipment can indicate a possible malfunction.

PROBLEM	POSSIBLE CAUSE	RECOMMENDED REMEDY (INDICATIVE)
Beating	➡ Surge operation	➡ Increase the flow rate
Presence of high frequency vibrations	➡ Ball bearings damage	➡ Replace the ball bearings (§ 5.2.4)
Increase of the vibrations level following to a maintenance operation		➡ Check and correct the alignment (§5.2.3)
		➡ Check and correct the alignment of the mounting feet of the machine and those of the motor with the corresponding supports of the baseplate
		➡ Check and correct the contact of the baseplate with the resilients pads or the anchor bolts
Regular noise following: • Operation at excessive temperature • Presence of unforeseen particles or foreign bodies in the processed fluid		➡ General overhaul of the machine. Consult CONTINENTAL INDUSTRIE (internal zone must be unchanged)

6.3 EXCESSIVE OUTLET TEMPERATURE

Except particular cases, outlet temperatures are considered as excessive when whatever authorized flow, they exceed the values of 140°C.

POSSIBLE CAUSE	RECOMMENDED REMEDY (INDICATIVE)
Increase of inlet temperature	➡ Check and correct upstream process
Decrease of fluid processed flow	➡ Increase the flow rate

6.4 EXCESSIVE BEARING TEMPERATURE

The temperature of the bearings measured on the external ring is considered excessive when it is above 120°C.

POSSIBLE CAUSE	RECOMMENDED REMEDY (INDICATIVE)
Excessive outlet temperature	➡ Check and correct process
Lack of lubrication	➡ Check and correct

6.5 EXCESSIVE ABSORBED POWER

Power absorption is proportional to the mass flow of the fluid processed.

Any decrease of pressure drop, at inlet or outlet, leads in a capacity increase and, therefore, the one of the consumed power.

POSSIBLE CAUSE	RECOMMENDED REMEDY (INDICATIVE)
Upstream or downstream valves not correctly adjusted	➡ Check and correct §4.3
Modification of inlet conditions (increase of molecular weight)	➡ Decrease the flow rate
Upstream or downstream valves too open (difficulties to start)	➡ Check and correct §4.3
Presence of water inside the machine	➡ Bleed by removing the drain plugs of all intermediate parts and the outlet head. Put back the plugs (+ PTFE film) once bleeding carried out.





6.6 HIGH VIBRATION LEVEL

Vertical, horizontal and axial vibration values measured on the bearing housings can be assessed by using the graph shown in Fig. 6.1.

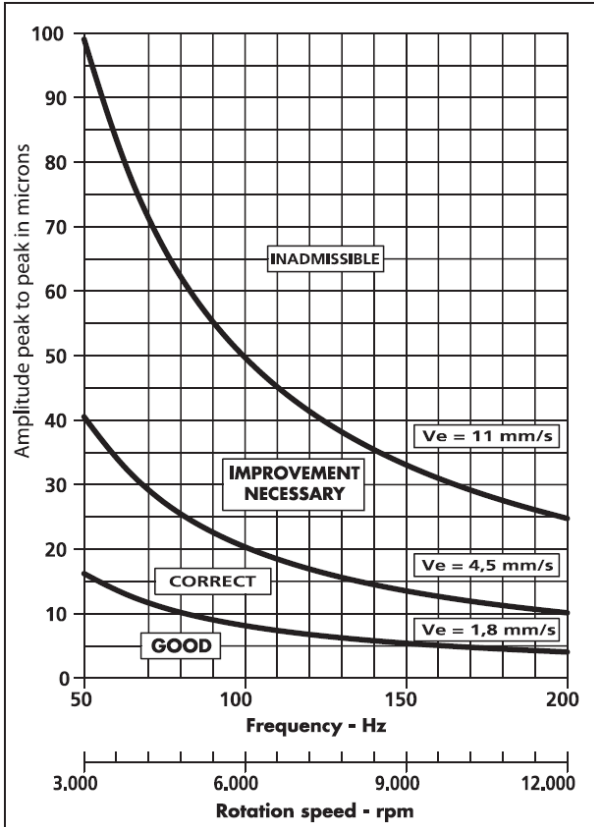

Fig. 6.1

The areas in the graph are defined by the curves of the three effective reference velocities (R.M.S.). Naturally, the amplitude values vary depending on the speed of rotation of the machine.

POSSIBLE PROBLEM AND CAUSE	RECOMMENDED REMEDY (INDICATIVE)
Defective ball bearings	➡ Change the ball bearings (§ 5.2.4)
Misalignment following operation of maintenance	➡ Check and correct alignment (§ 5.2.3)
Bad contact between mounting feet of the machine and the motor with the baseplate, following operation of maintenance	➡ Check and correct the contact of compressor mounting feet and those of the motor with the baseplate
Bad contact between the baseplate and its supports on the foundations	➡ Check and correct the contact between the baseplate and the corresponding supports
Defective belts	➡ Change the set of belts §5.2.2
Rotor elastic deformation due to excessive belts tension during operation of maintenance	➡ Check an correct §5.2.2
Rotor permanent deformation due to excessive belts tension during operation of maintenance	➡ General overhaul of the machine. Consult CONTINENTAL INDUSTRIE
Rotor unbalance following defect modifying its geometry	➡ General overhaul of the machine. Consult CONTINENTAL INDUSTRIE
Vibrations transmitted to the foundations due to start-up of nearby equipment	➡ Check and reinforce the relative insulation





7. SUPPORT

Requests for technical support should be addressed to:

CONTINENTAL INDUSTRIE	
Route de Baneins 01990 Saint Trivier sur Moignans, France	
TEL. :	+33 (0)4 74 55 88 77
FAX :	+33 (0)4 74 55 86 04
Email :	export@continental-industrie.com

7.1 JOBSITE INTERVENTION

All running repairs, i.e those not requiring the replacement of impellers, the shaft or stator parts (heads and/or diffusers), can be conveniently carried out on site by maintenance service personnel or external workshop personnel.

Naturally, it is also possible to request the on-site services of specialized CONTINENTAL INDUSTRIE personnel.

The services will be provided on the basis of tariff in force to the date of the intervention and will have to be the subject of a purchase order in due form.

7.2 WORKSHOP SERVICE

If the repair requires the replacement of impellers, the shaft or stator parts (heads and/or diffusers), the machine needs to be completely stripped and the dynamic rebalancing of the rotor needs to be carried out.

Where the maintenance service or the external workshops available are not able to carry out the operation, it may be appropriate to send the machine to our workshop for an overhaul; this will be carried out on the basis of acceptance by the client of an estimate given for this work.

During overhaul:

- The machine is completely dismantled
- All the parts are cleaned, checked and replaced if necessary
- Rotor is balanced dynamically
- The revised machine is tested mechanically
- The machine is painted.

All the replaced parts of a revised machine are guaranteed 6 months.





BLOWERS & EXHAUSTERS INSTALLATION, OPERATION & MAINTENANCE MANUAL
CONTINENTAL INDUSTRIE S.A.S
ROUTE DE BANEINS - 01990 SAINT TRIVIER SUR MOIGNANS - FRANCE